

WT1D-107 WELDING TABLE

Order Code W08453



Due to the weight of the table, it is highly recommended that you have a second person to assist during the build of the table, being made from steel it is heavy and help should be obtained to avoid any injuries. Always remember to wear the appropriate PPE when working with metal and welding equipment. Refer to your welder manufacturers recommendations for the correct settings for your welder to suit the material thickness.

Suggestion of what you will need

Note - this assembly guide is merely a recommendation and should not be followed blindly, if you do not have the equipment or the experience necessary to complete this project you should consider seeking advice from a professional.

- 24pcs of M10 or M12mm x 75mm threaded bolts, nuts & washers.
- 'G' Clamps (or alternative) with an opening of at least 100mm to secure the legs in place during welding.
- Timber planks to assist in raising the table surface off the bench during assembly.
- MIG or TIG welder
- Angle grinder fitted with a fine flap disc
- Soft face hammer to help assemble components
- Engineers file, spanners or shifting spanners

NOTE: You may consider to use other methods and tools to help complete you project, the above list is just a suggestion. read through these instructions before starting the assembly process.

Getting Started

Before starting the assembly ensure you have the correct tools & equipment to successfully assemble the table whilst making sure you are wearing the appropriate Safety PPE.



Check for Burrs

It is normal for the components to have small burrs or minor imperfections as part of the laser cutting process. While wearing protective gloves, check the edges of the individual pieces and visually inspect them for any small burrs. If you do happen to find one, use a file to remove any burrs, being careful not to remove too much excess material as it may affect the end result.

Clean Components

The components are supplied with a thin layer rust preventative oil coating to protect it from rust, however, this film can affect the quality of the welds if it isn't removed. Before you start assembling the table, ensure you wipe the individual pieces down with an appropriate oil & grease remover.

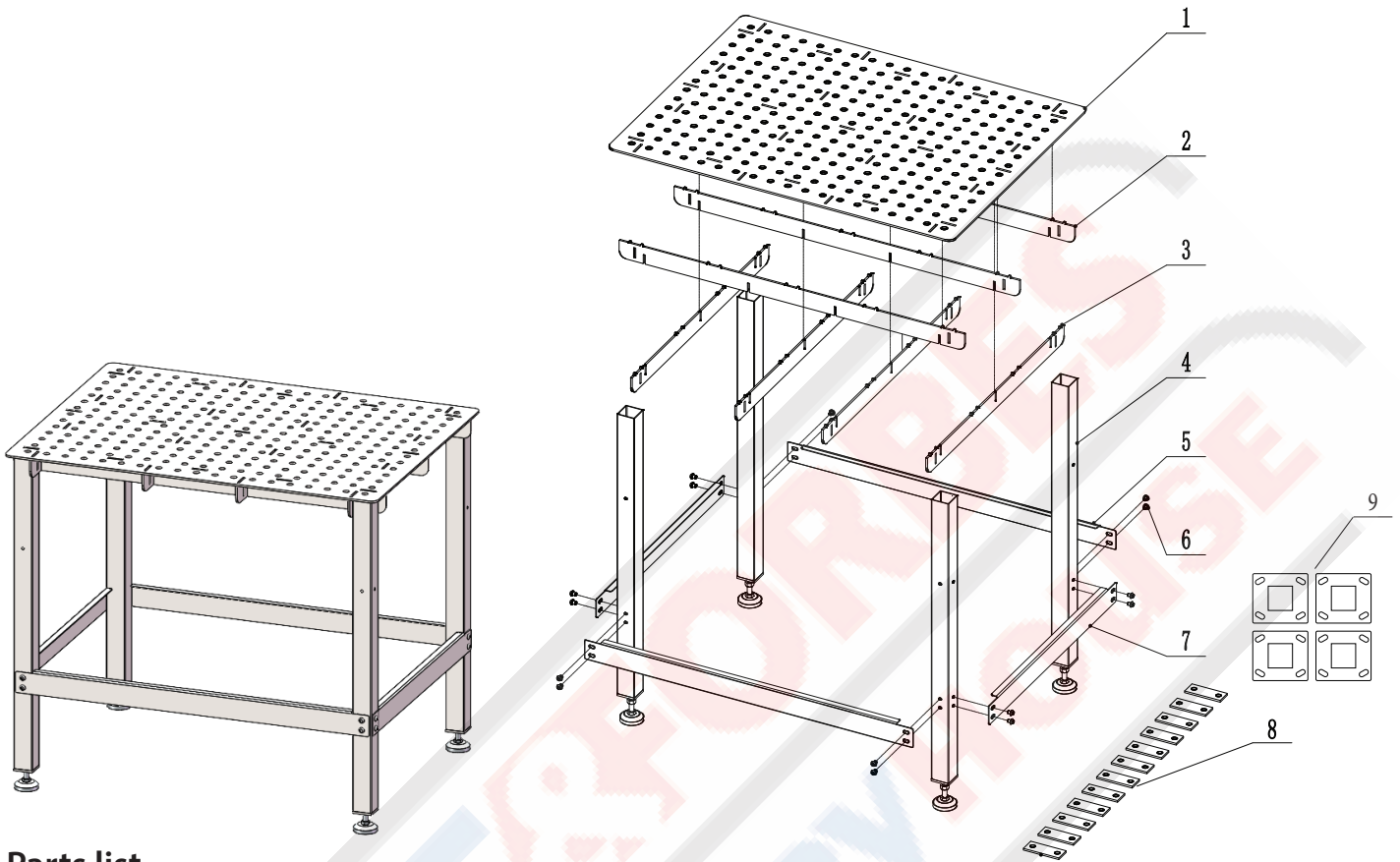

Parts list

Please check that you have all the below parts before you assemble this product

Part	Image	Part	Image
1. Table Top Qty:1		7. Shot Leg Brace Qty:2	
2. Long Ribs Qty:3		8. Assembly Straps Qty:12	
3. Cross Ribs Qty:4		9. Castor Mounting Plates Qty:4	
4. Legs with Feet Qty:4			
5. Long Leg Brace Qty:2			
6. Bolts Qty:16			

Step 1

Place the tabletop on top of timber planks or, alternatively, sawhorses. It is best to have the timbers spaced evenly to distribute the weight evenly and reduce distortion during assembly.

Ensure the tabletop is level and doesn't rock from side to side; this will help ensure the components fit together correctly.

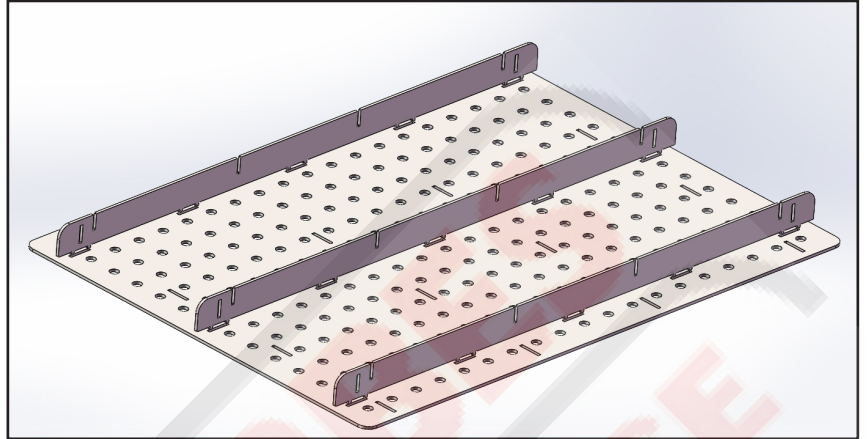
**Step 2**

Insert the ribs into the underside of the tabletop as shown; they should fit together firmly with only a small amount of clearance between the components. Use a soft-face hammer to lightly tap the components into place. If they do not fit correctly the first time, be sure to check for any small burrs and then try again.

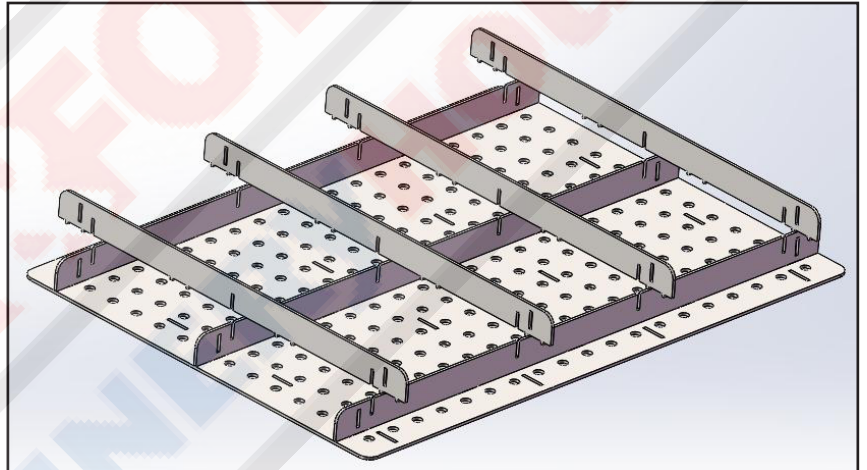
**Step 3**

To aid in assembly, your welding table comes supplied with 12 pieces of pre-drilled flat bar assembly straps to span across the webbing rib joins on the underside of the table. Use the M10-M12 bolts and the assembly straps to secure the ribs to the tabletop. Ensure you do not overtighten the bolts; otherwise, uneven forces are applied to different parts of the table, which can lead to twisting of the table and a less than desirable final result.

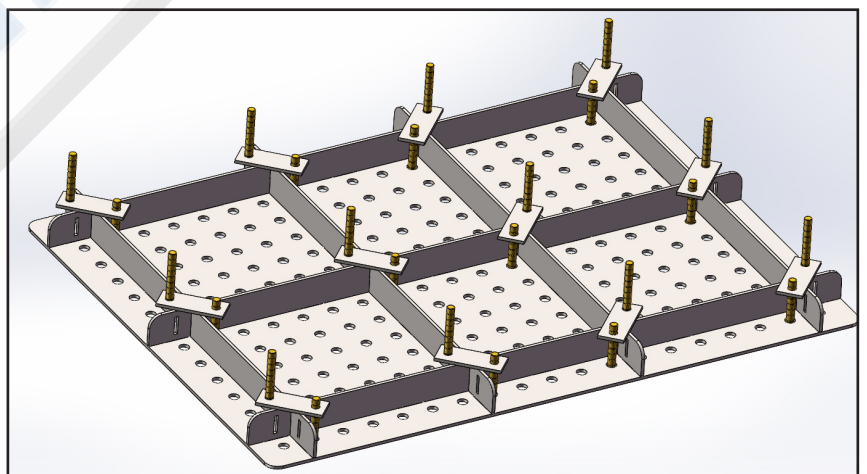

Step 4

With the assistance of a second person, carefully turn the table over so that the table surface is upright, and ensure the welding table is placed on a flat, level surface. Before doing any welding, check the flatness with a builders level or straight edge. With the help of a small flashlight, You can check if there are any gaps between the underside of the table surface and the webbing ribs to ensure they are secured correctly, there should be no gaps between the tabletop and the ribs. The most likely cause is a small burr, or the bolts have not been tightened. If this is the case, disassemble, remove the burr and reassemble. Once again, ensure you do not overtighten the bolts, otherwise uneven forces are applied to different parts of the table, which can lead to a twisting of the table, leading to a less-than-desirable final result.

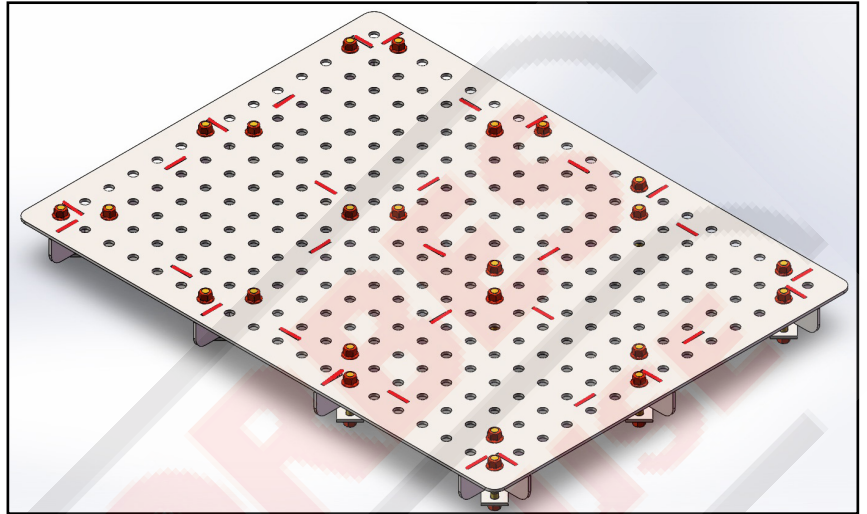

Step 5

Once you are happy with the assembly and flatness, weld the areas highlighted in red in the sequence as indicated, and weld with a spiral motion so that the two pieces fuse together correctly. Finish welding all the green areas in a clockwise rotation. Less is more when welding this table together. More welding means more heat and higher chances of warping the table surface.

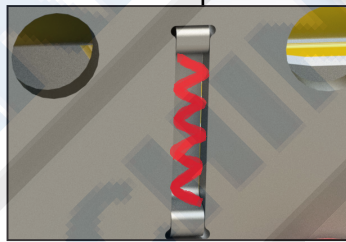
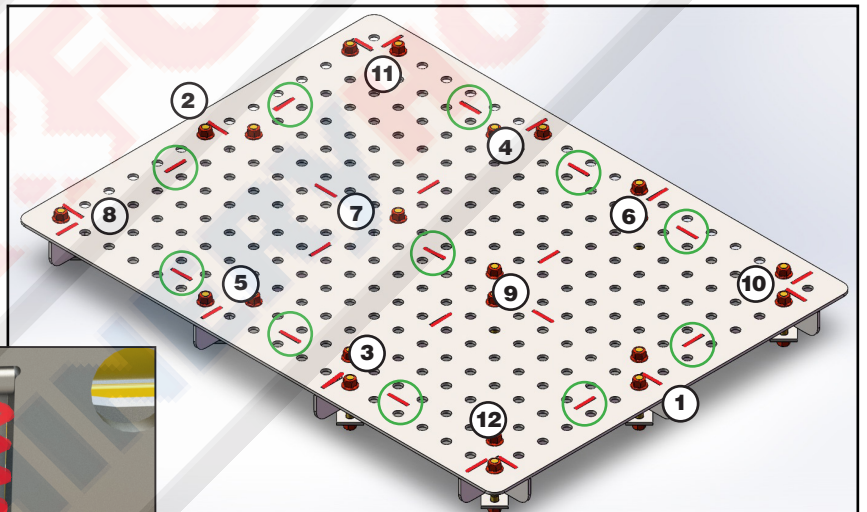

Step 6

The 50 x 50mm steel legs come standard with adjustable feet fitted, plus we also supply caster mounting plates. If you want your welding table to stay on the adjustable feet, then proceed to step 7. If you want your welding table to be mobile, simply cut the legs to the desired length to suit the finished table height you require, allowing for the height of the caster wheels. Weld on the caster mounting plates as shown, and bolt on your optional caster wheels.

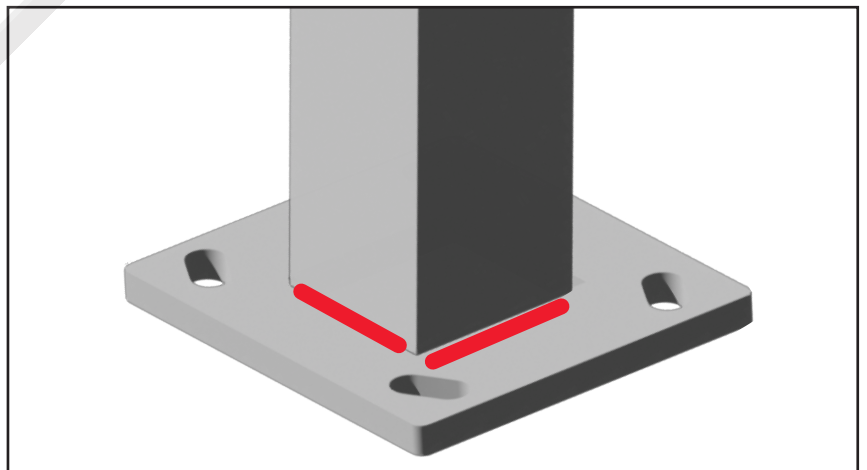

Step 7

Once the table has cooled, remove the bolts and assembly straps. Again, with the assistance of a second person, turn the table over with the webbing ribs facing up. Clamp the tube legs into each corner as shown, ensuring the threaded holes are in the correct positions to suit the leg bracing. Lightly clamp the legs into each corner as shown, then bolt the leg bracing into place (do not fully tighten the bolts). Check that the legs are square and level, then proceed to weld as shown. Once finished welding, tighten the leg bracing.

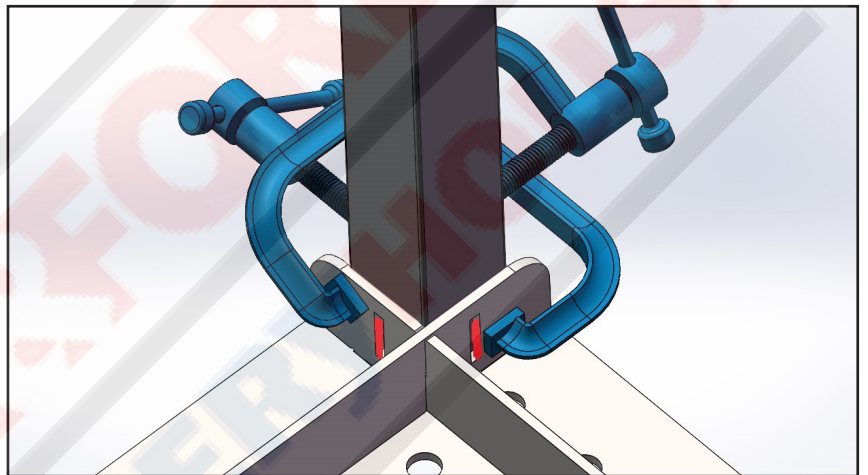
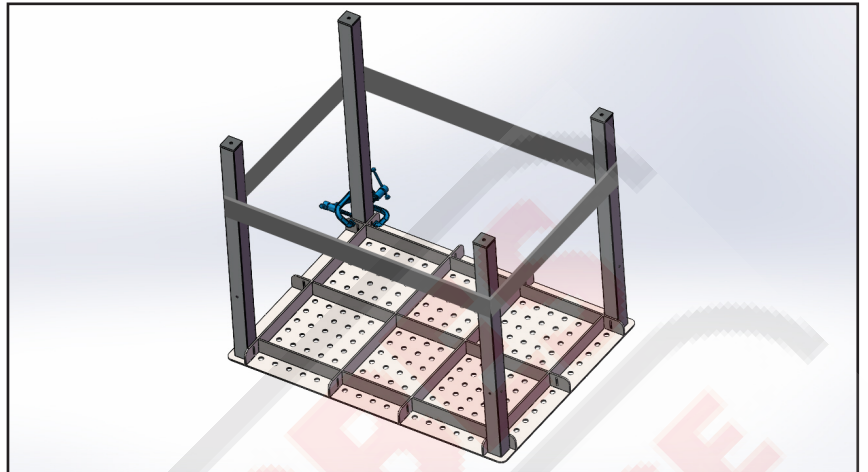

Step 8

The assembly is now complete. With the assistance of the second person, carefully turn the table over, put it in your desired position, and adjust the levelling feet, check all bolts are tighten and components are secure. Your welding table is now ready for use.

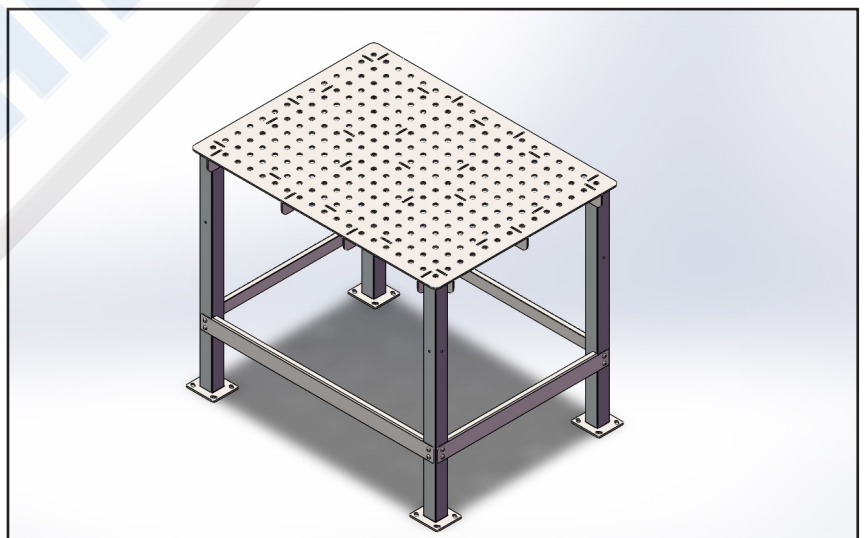

* Shown with caster mounting plates